

MANGUITOS

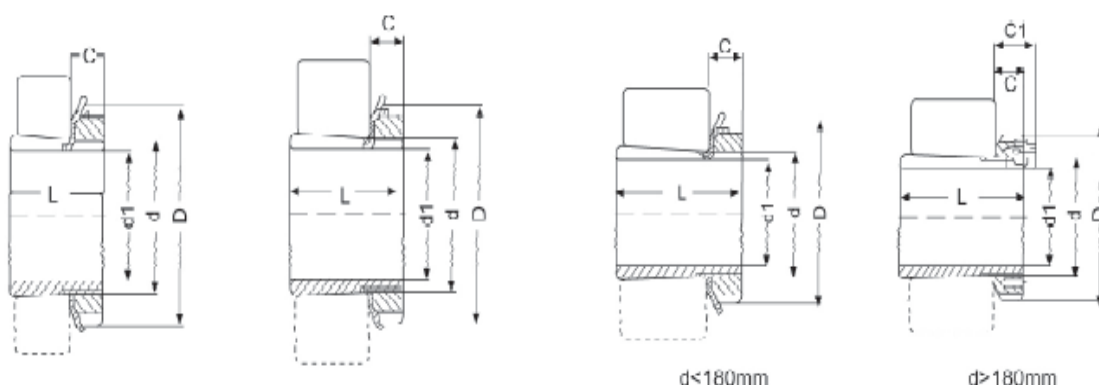

H2 (HE, HS, HA) Series

Bearing No	d	d1	L	D	C	AN/KM AW/MB	Weight (kg)
H204	20	17	24	22	7	4	0.041
H205	25	20	28	38	8	5	0.070
H206	30	25	27	45	8	6	0.099
H207	35	30	29	52	9	7	0.126
H208	40	35	31	58	10	8	0.174
H209	45	40	33	65	9	9	0.227
H210	50	45	35	70	10	10	0.274
H211	55	50	37	75	11	11	0.308
H212	60	55	38	80	12	12	0.346
H213	65	60	40	85	13	13	0.401
H214	70	60	41	92	14	14	0.503
H215	75	65	43	98	15	15	0.707
H216	80	70	46	105	17	16	0.882
H217	85	75	50	110	18	17	1.02
H218	90	80	52	120	18	18	1.19
H219	95	85	55	125	19	19	1.37
H220	100	90	58	130	20	20	1.49
H221	105	95	60	140	20	21	1.72
H222	110	100	63	145	21	22	1.93
H304	20	17	28	32	7	4	0.045
H305	25	20	29	38	8	5	0.075
H306	30	25	31	45	8	6	0.109
H307	35	30	35	52	9	7	0.142
H308	40	35	36	58	10	8	0.189
H309	45	40	39	65	11	9	0.248
H310	50	45	42	70	12	10	0.303
H311	55	50	46	78	12	11	0.346
H312	60	55	47	80	13	12	0.394
H313	65	60	50	85	14	13	0.458
H314	70	60	52	92	14	14	0.723
H315	75	65	55	98	15	15	0.831
H316	80	70	58	105	17	16	1.03
H317	85	75	63	110	18	17	1.18
H318	90	80	65	120	18	18	1.37
H319	95	85	68	125	19	19	1.56

H3 (HE, HS, HA) Series

Bearing No	d	d1	L	D	C	C1	AN/KM AW/MB	Weight (kg)
H320	100	90	71	130	20	--	20	1.69
H321	105	95	74	140	20	--	21	1.95
H322	110	100	77	145	21	--	22	2.18
H2304	20	17	31	32	7	--	4	0.049
H2305	25	20	35	38	8	--	5	0.067
H2306	30	25	38	45	8	--	6	0.126
H2307	35	30	43	52	9	--	7	0.165
H2308	40	35	46	58	10	--	8	0.224
H2309	45	40	50	65	11	--	9	0.280
H2310	50	45	55	70	12	--	10	0.362
H2311	55	50	60	78	12	--	11	0.420
H2312	60	55	62	80	13	--	12	0.481
H2313	65	60	65	85	14	--	13	0.557
H2314	70	60	68	92	14	--	14	0.887
H2315	75	65	73	98	15	--	15	1.05
H2316	80	70	78	105	17	--	16	1.28
H2317	85	75	82	110	18	--	17	1.45
H2318	90	80	88	120	18	--	18	1.65
H2319	95	85	90	125	19	--	19	1.93
H2320	100	90	97	130	20	--	20	2.15
H2321	105	95	101	140	20	--	21	2.46
H2322	110	100	105	145	21	--	22	2.74
H2324	120	110	112	155	22	--	24	3.19
H2326	130	115	121	165	23	--	26	4.00
H2328	140	125	131	180	24	--	28	5.55
H2330	150	135	139	195	26	--	30	6.63
H2332	160	140	147	210	28	--	32	9.14
H2334	170	150	154	220	29	--	34	10.2
H2336	180	160	161	230	30	--	36	11.3
H2338	190	170	169	240	31	--	38	12.6
H2340	200	180	176	250	32	--	40	13.9
H2344	220	200	188	280	35	44	44	16.7
H2348	240	220	199	300	37	46	46	19.7
H2352	260	240	211	330	39	49	49	24.2
H2356	280	260	224	350	41	51	51	27.6